

厦门大学机器人队

先期培训 · 执行器



厦门大学机器人队

微控制器

micro control unit -----MCU

- 1 供电3.3V, 只提供控制信号, 输出功率有限
- 2 支持CAN, UART, IIC, SPI等通信方式
- 3 提供12个定时器

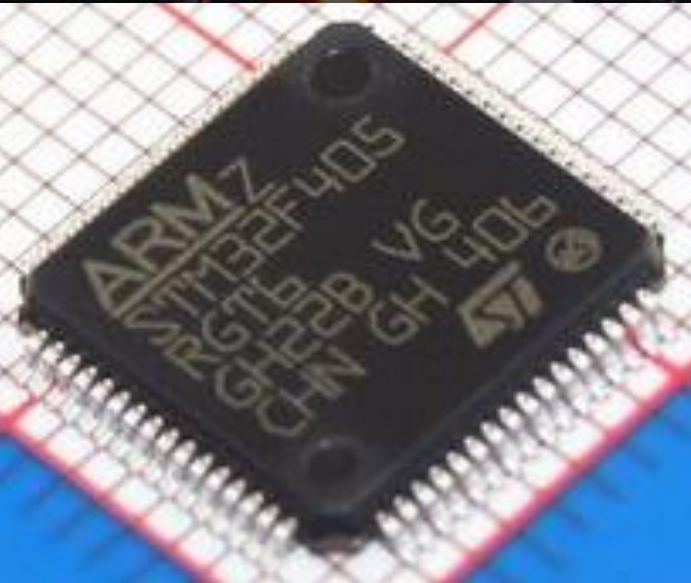

执行器

驱动的意思:

**控制器本身所提供的能量不足以带动执行器工作，
控制器本身只产生控制信号，执行器由其他器件提供能量。**

- 
- 电机
 - 电调
 - 气缸
 - 电磁阀
 - 舵机
 - 推杆



The background features several technical drawings of a motor assembly on a blue grid. At the top, there are two circular diagrams showing the stator and rotor. Below them is a rectangular diagram of a motor housing with a central square cutout. At the bottom, a larger drawing shows a motor with a terminal box on top, with the 'RECHERCHES & DÉVELOPPEMENTS' logo visible on the side.

先期培训 · 执行器

电机

基础知识

电生磁

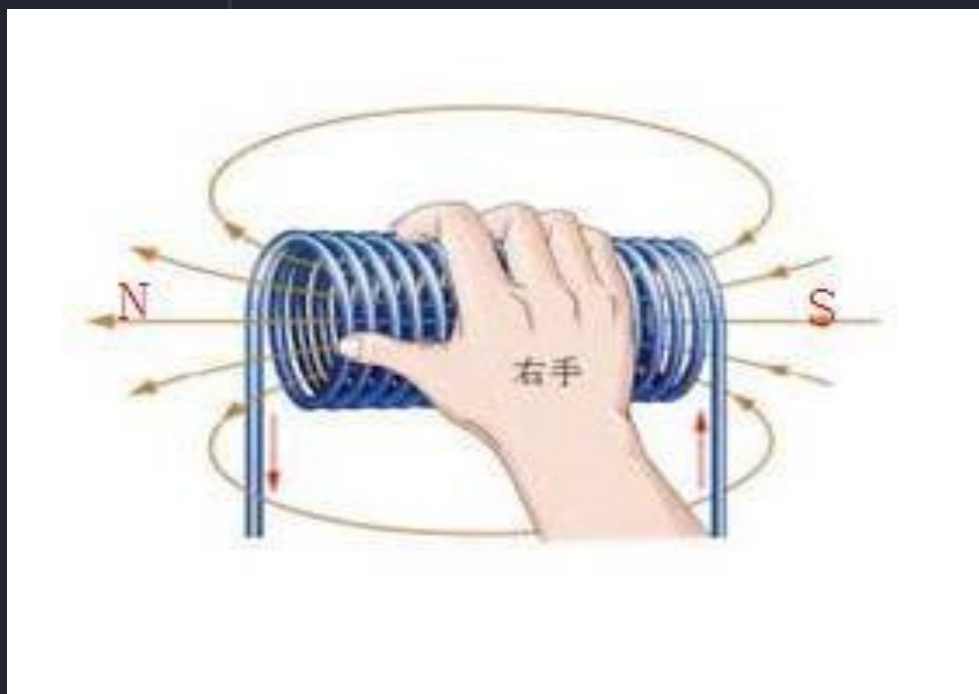

电流在磁场中受力

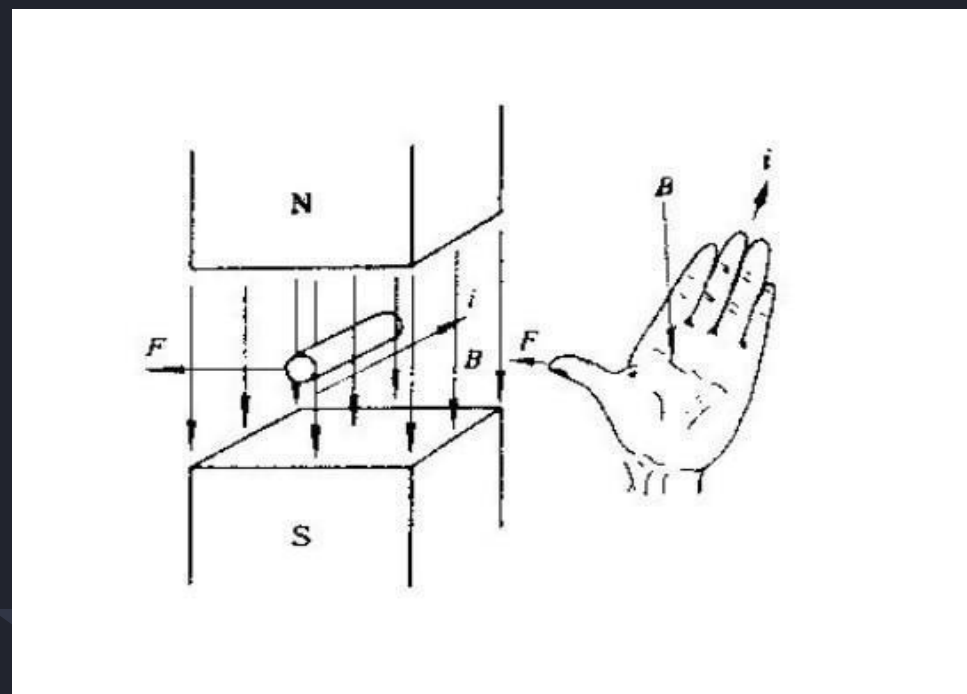

驱动无刷电机转动需要电调控制

转子
定子

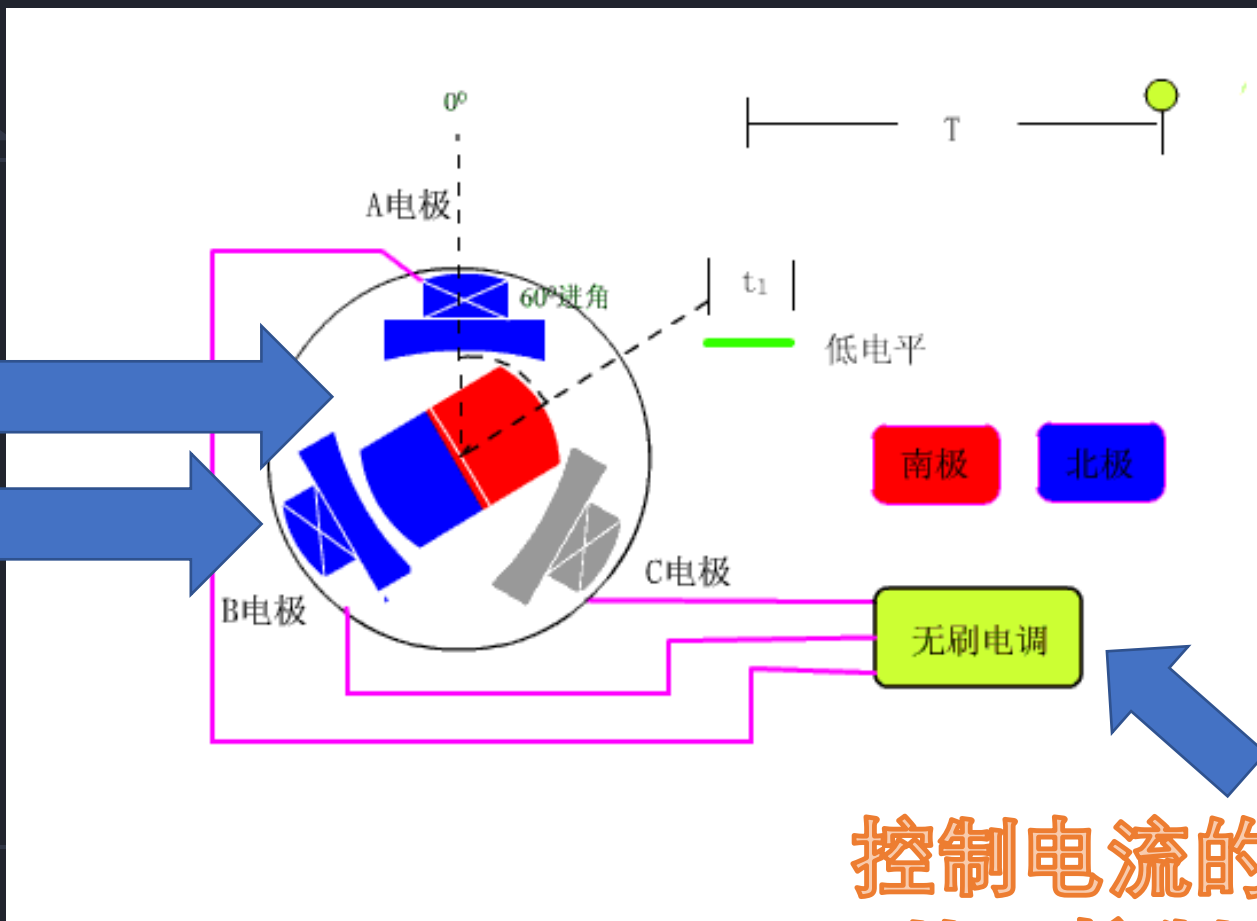

控制电流的大小和相位
从而控制电机的转速

电机的反馈----编码器原理

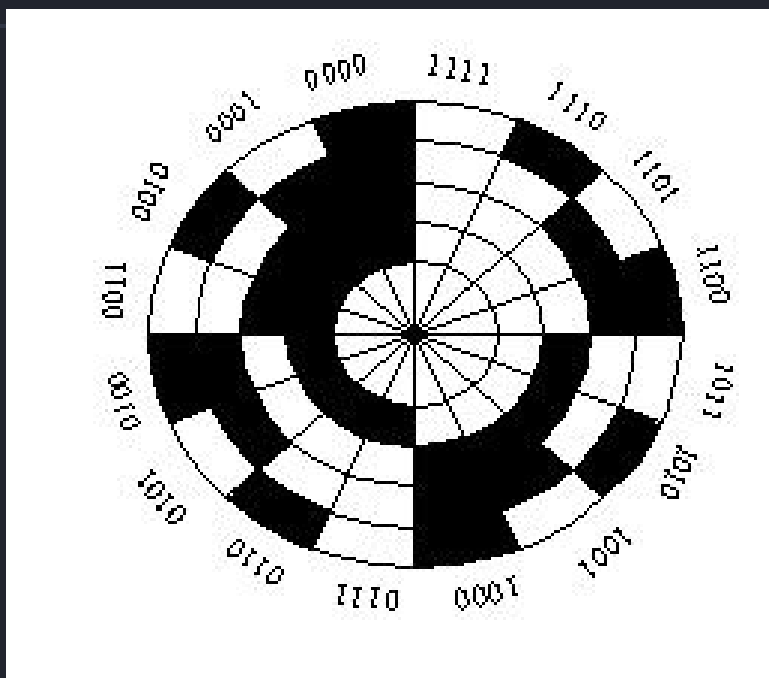
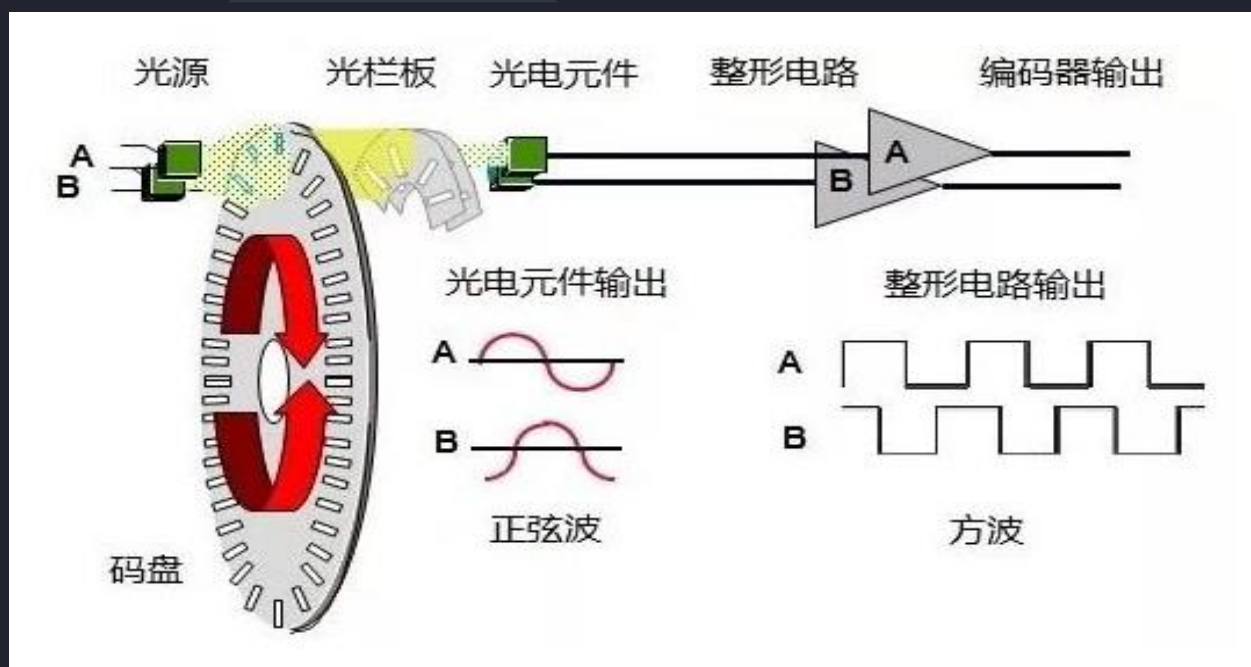

通过编码器可以知道电机的转速和旋转方向

C620电调

厦门大学机器人队·培训课件

M3508电机

实物图对应

自带编码器



<- 电机数据返回数据线
微控制器控制数据线->

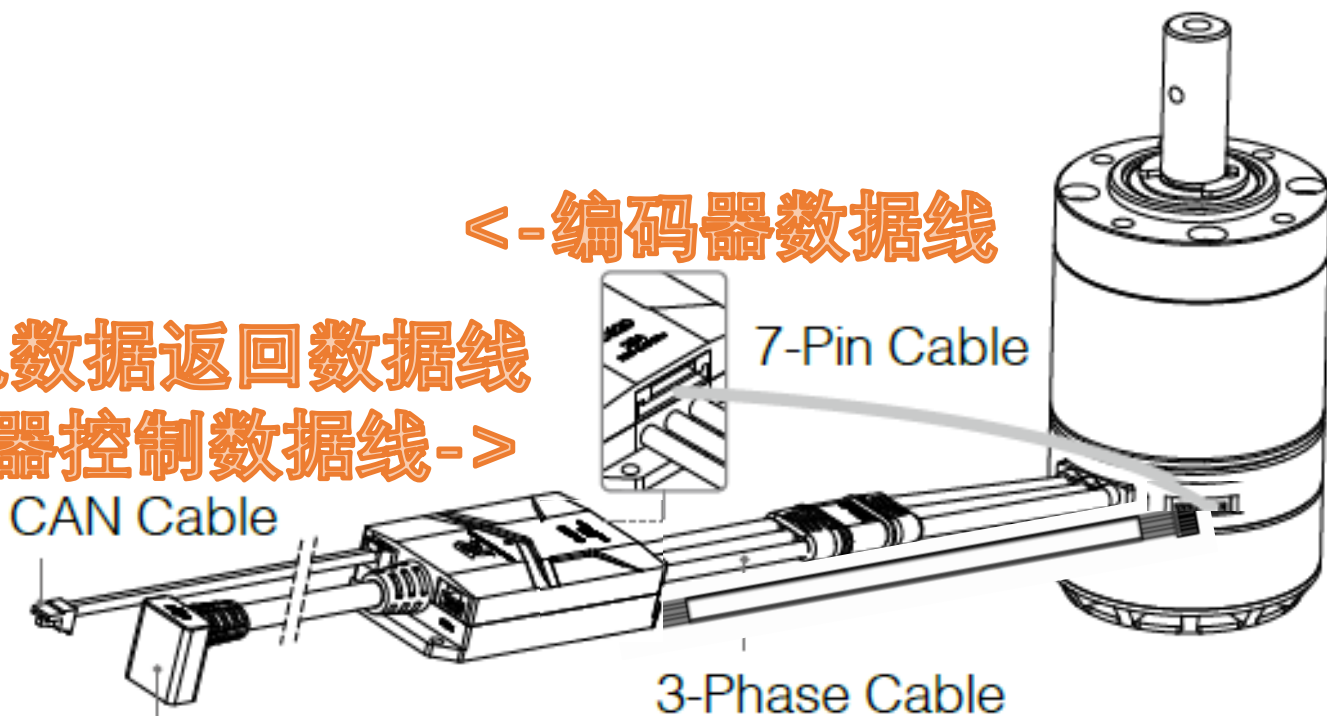

Power Supply Port
24V供电线->

三项电机驱动线->



GM6020电机结构



CAN通信控制端口

24V供电端口

GM6020电机

扭矩大，用于云台



M3508电机

转速高，用于地盘



The background features several technical drawings of a robotic gripper. At the top, there are two circular views of the gripper's end effector, showing a complex arrangement of fingers and a central hub. Below these, there is a rectangular view of the gripper's body, showing a central square opening and four mounting points. At the bottom, there is a side-view drawing of the gripper's main body, showing a cylindrical shape with a square top and a logo on the side. The drawings are rendered in white lines on a blue grid background.

先期培训 · 执行器

气缸

气缸

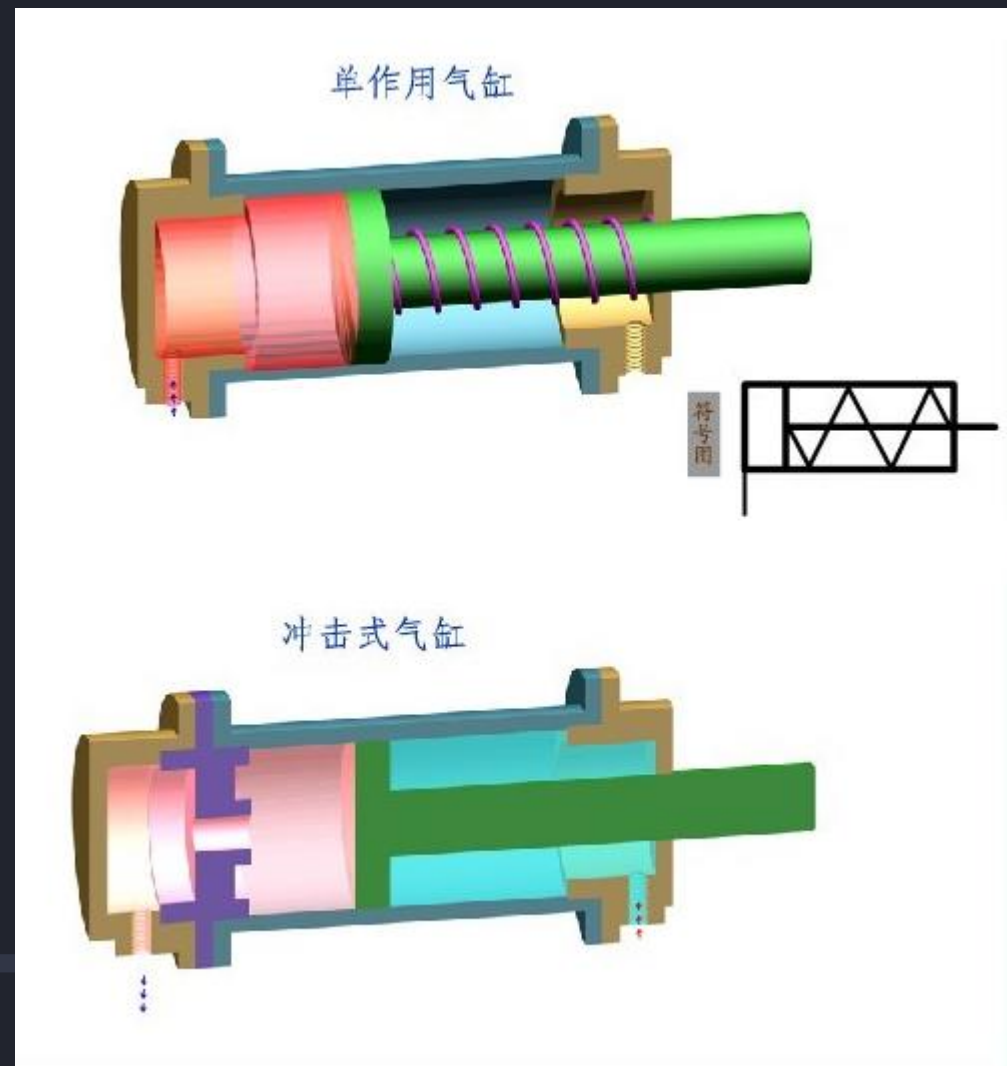

The background features several technical drawings of a valve assembly. At the top, there are two circular cross-sectional views of the valve's internal components, showing a complex arrangement of seals and ports. Below these, on the left, is a square flange with four mounting holes. At the bottom, a side-view drawing shows the valve's actuator and body, with a logo on the side that includes a stylized 'R' and the text 'RHEINOLD & BERTHOLD'.

先期培训 · 执行器

电磁阀

电磁阀

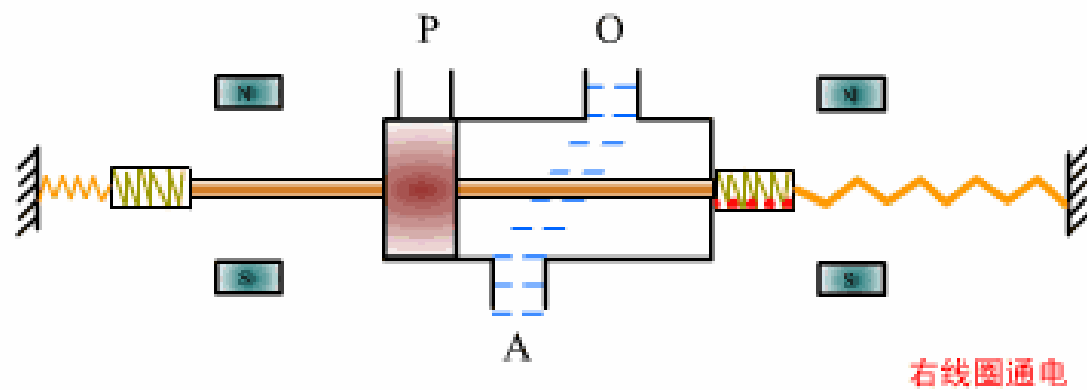

三位三通电磁阀



三極三

右线圈通电

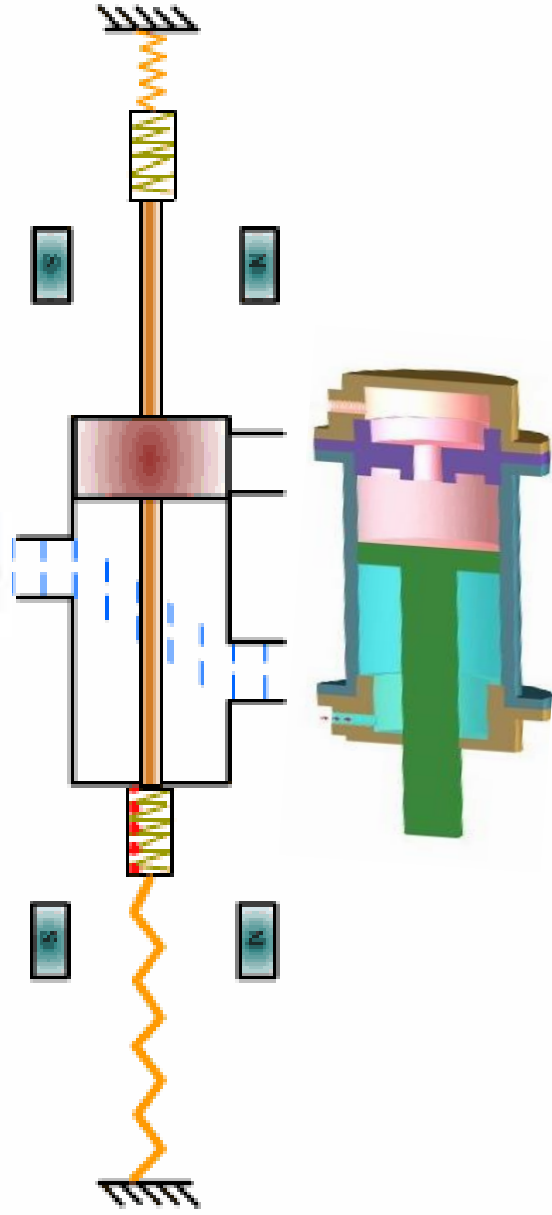



The background features several technical drawings of a robotic gripper system. At the top, there are two circular diagrams showing the gripper's end effector with various mechanical details and dimensions. Below these, there is a rectangular diagram of a gripper body with four mounting points. At the bottom, a larger, more detailed drawing shows the gripper assembly mounted on a robotic arm, with a 'RECHERCHES & DÉVELOPPEMENTS' logo visible on the side.

先期培训 · 执行器

舵机

PWM: Pulse Width Modulation

脉冲宽度调制

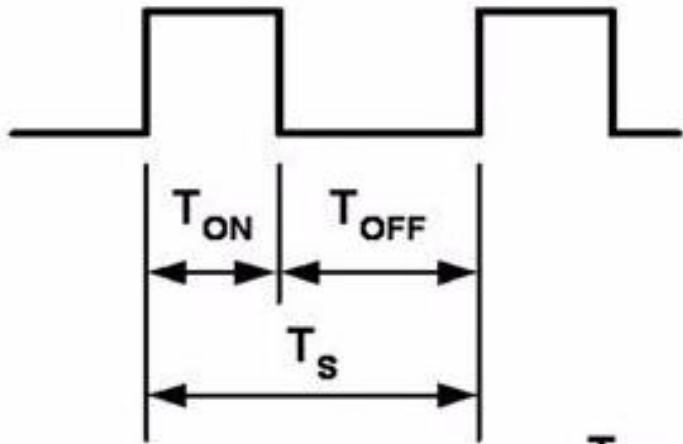

$$\text{Duty Cycle} = \text{Duty Ratio} = D = \frac{T_{ON}}{T_{ON} + T_{OFF}} = \frac{T_{ON}}{T_S}$$

Duty 占空比

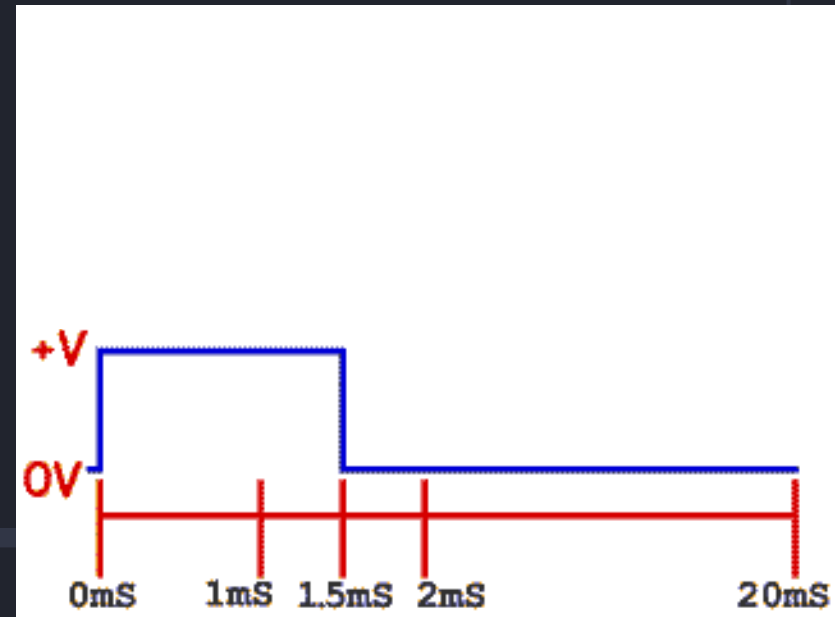

舵机

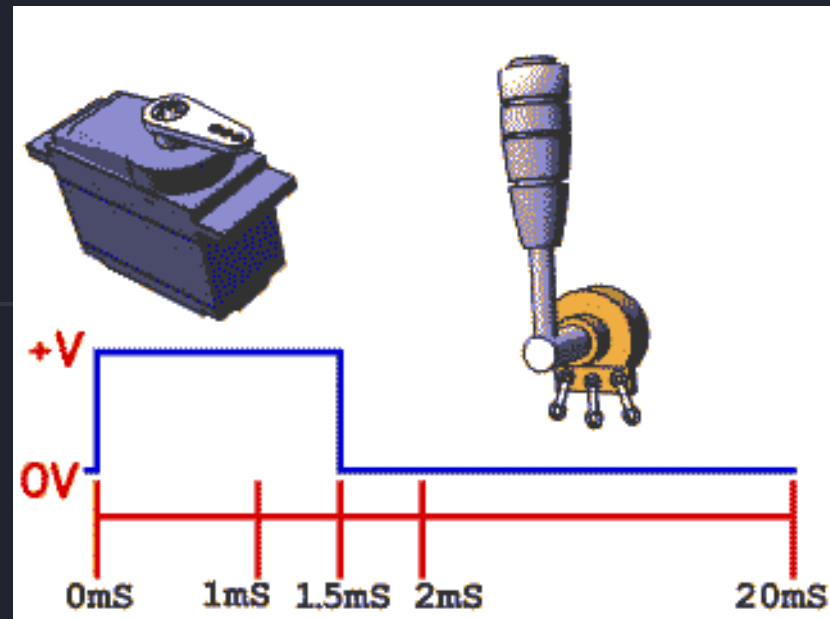

棕褐色地线
红色接电源
橙色PWM控制线

驱动电路——H桥电路

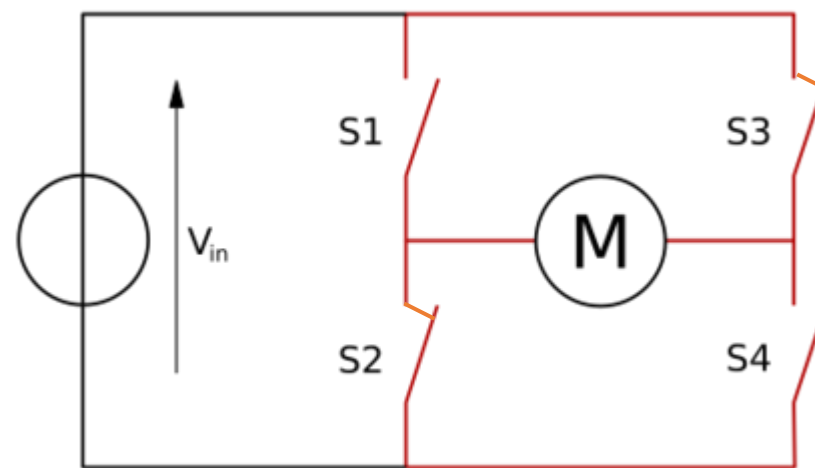
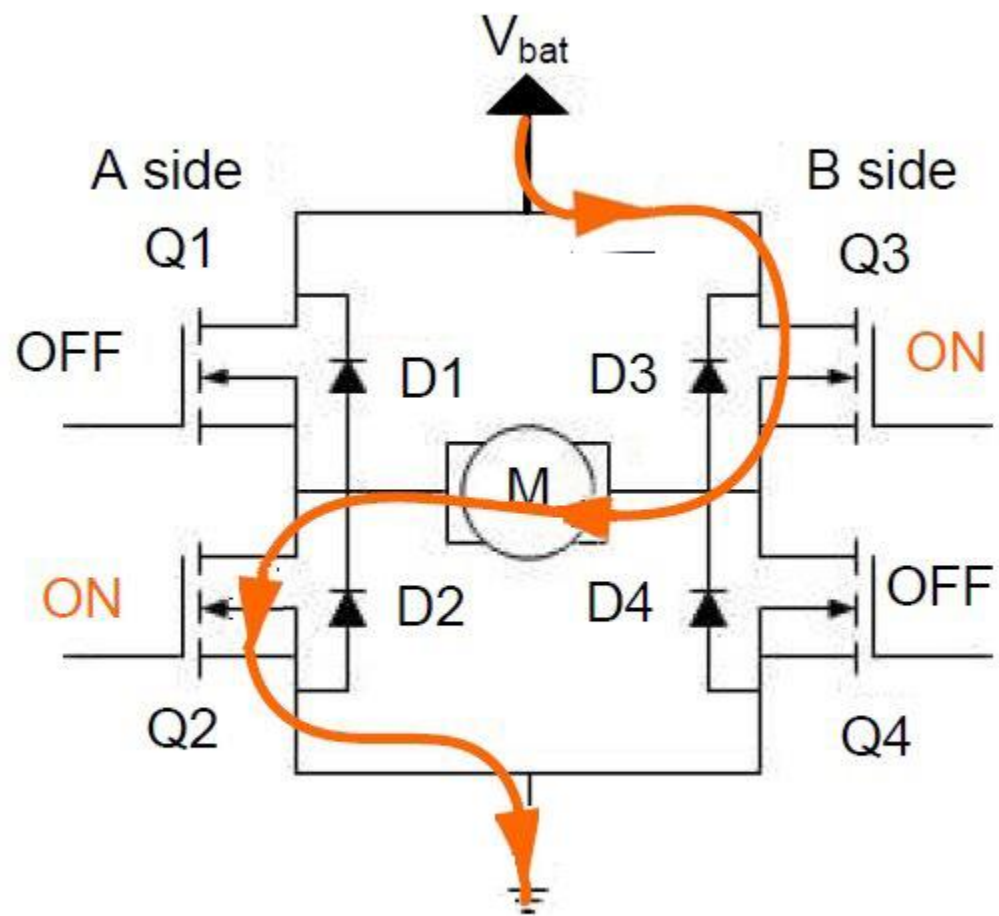

驱动电路——H桥电路

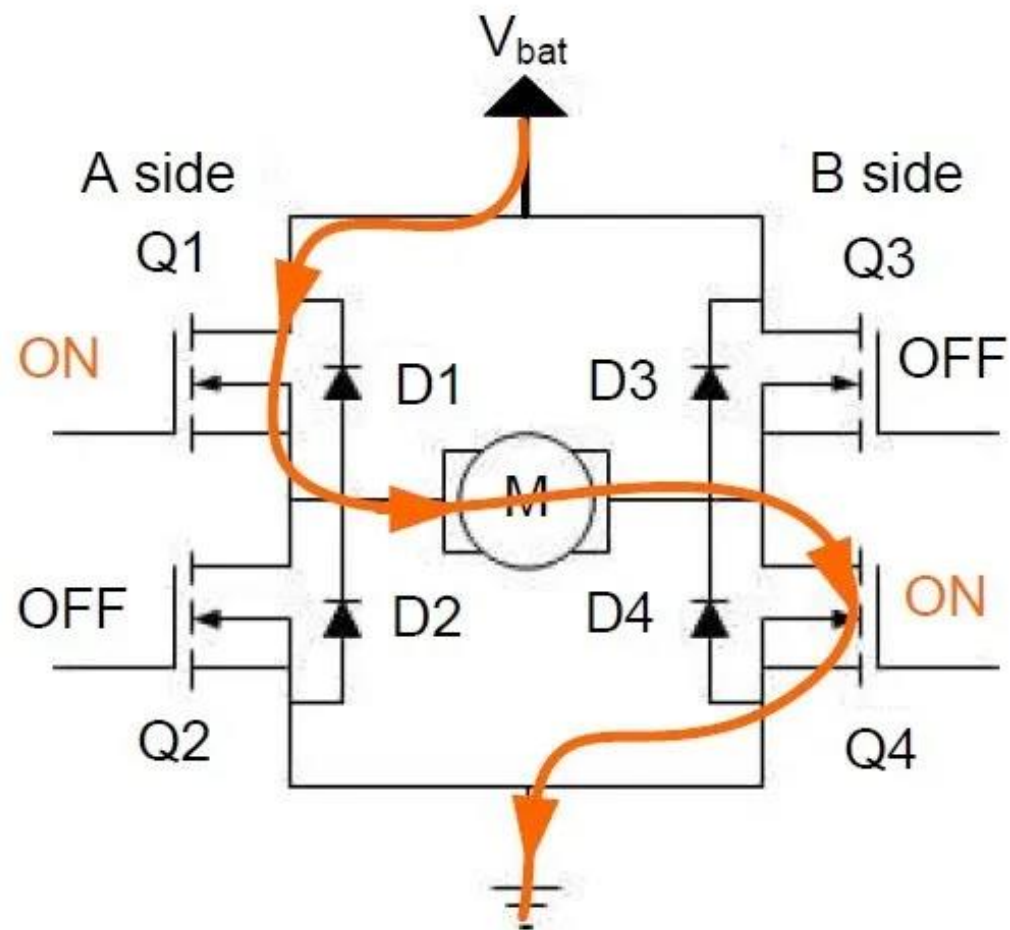
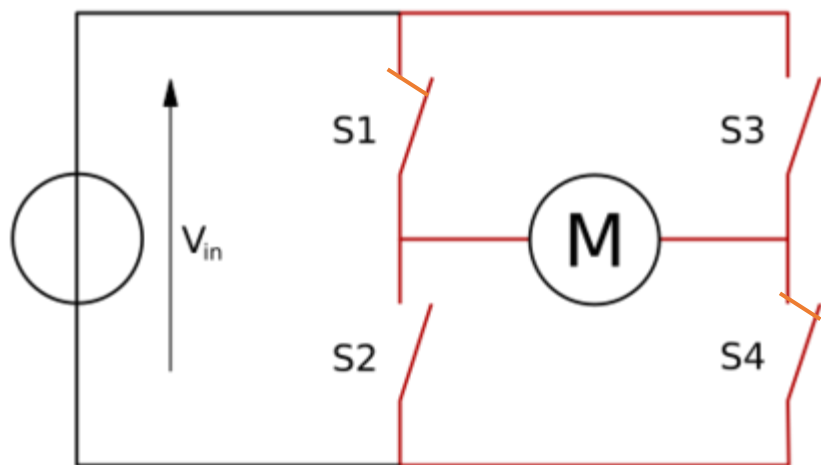

H桥芯片实物图

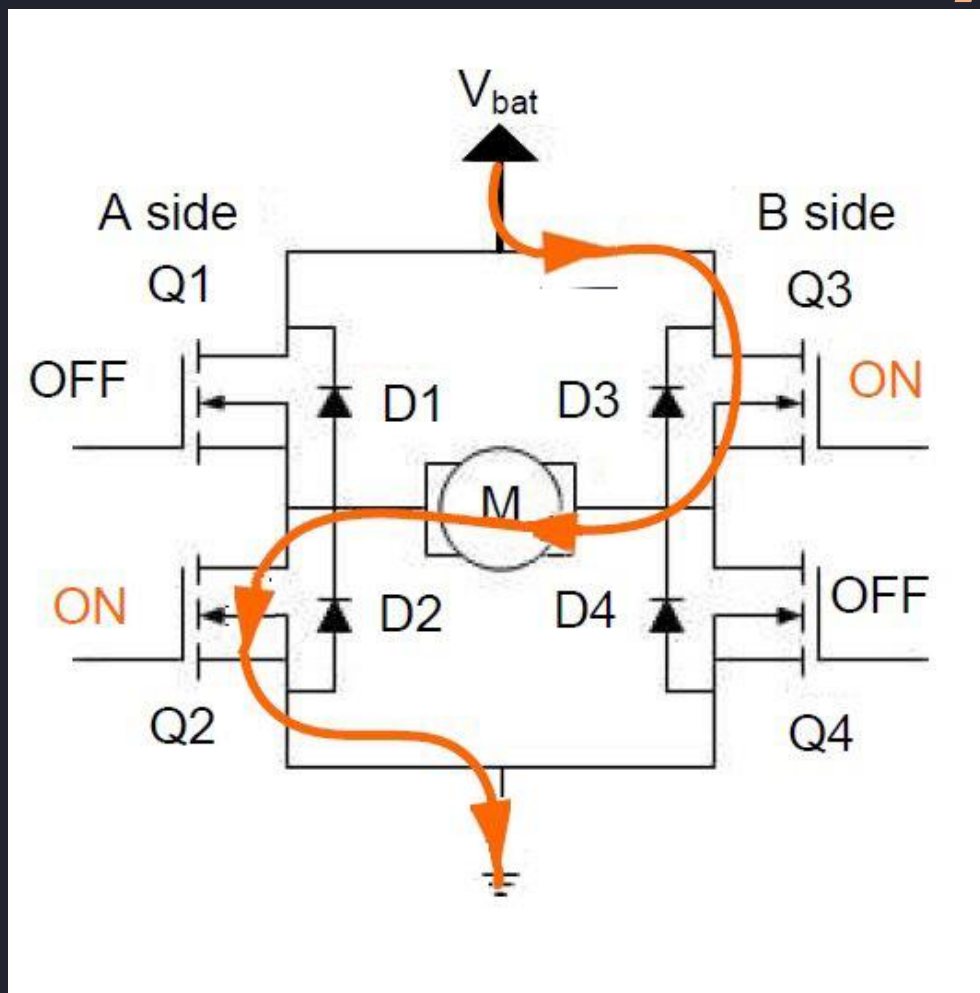



The image features a blue background with a white grid pattern. On the left side, there are several technical drawings of a robotic gripper system. At the top, two circular diagrams show the gripper's end effector from different perspectives. Below them is a rectangular diagram of the gripper's main body. At the bottom, a larger, more detailed drawing shows the gripper mounted on a robotic arm, with a motor and various mechanical components. A small text box is located near the top right of the grid area, containing the following text:

The MT2000 Accessories Kit includes several options and a terminal board, creating a complete production system driven by four independent motors.

先期培训 · 执行器

电推杆

电推杠

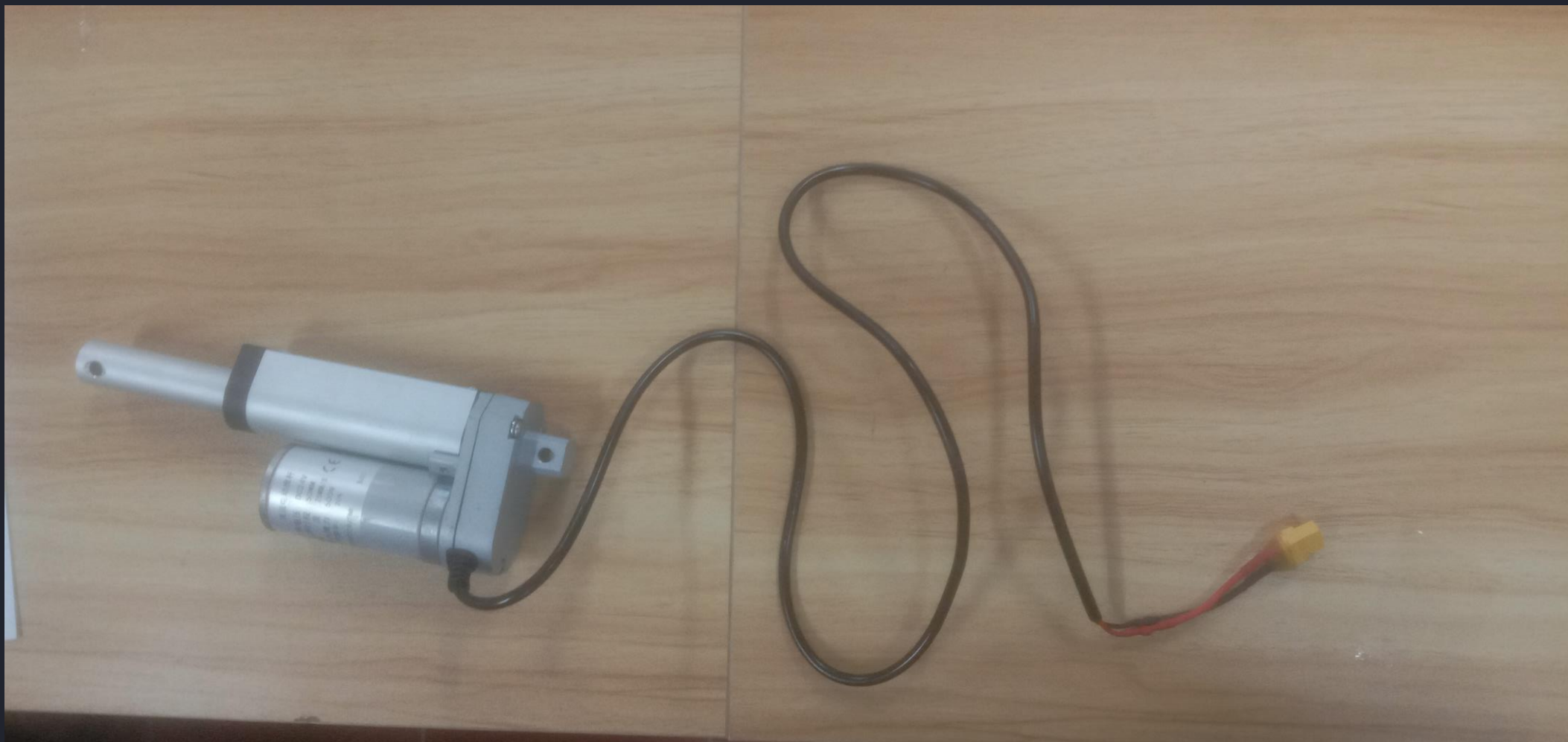

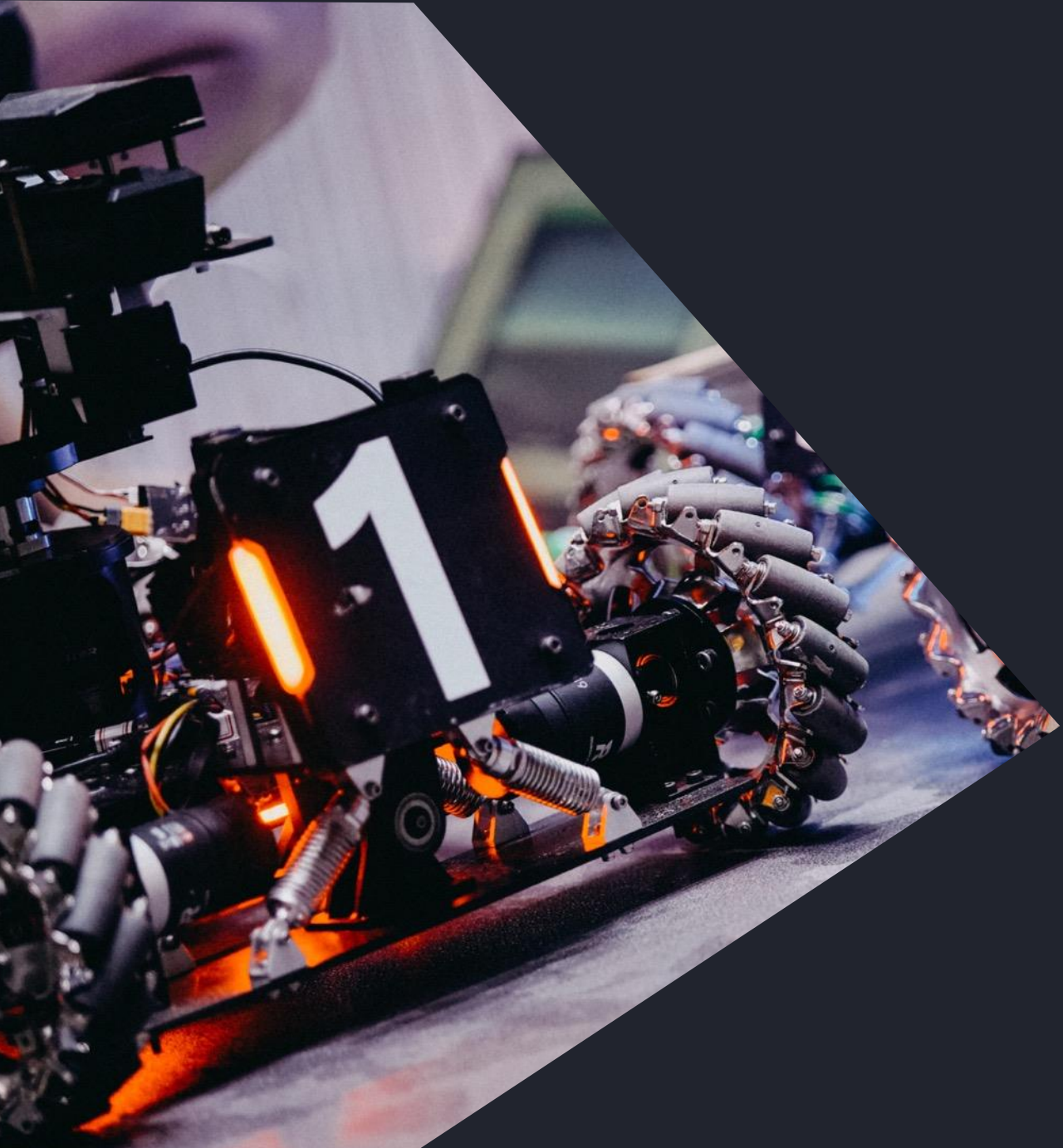

感谢观看

自强不息 止于至善